

Features & Benefits

- Small diameter - 400mm
- Designed for restricted space installations
- Dual handed connections
- Plug & lead models 2.4kW only
- Recessed plug fittings
- Safe for wall mounting - Wall mounting bracket 299120
- 7 year cylinder warranty¹

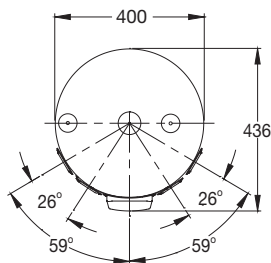

MODEL	191050 191050/P
Hot Water Delivery (L)	50
Element Rating (kW)	1.8, 2.4, 3.6
Relief Valve Pressure (kPa)	1400
Expansion Control Valve (kPa)	1200
Max Water Supply Pressure:	
with ECV (kPa)	960
without ECV (kPa)	1120
Water Connections	Rp ³ / ₄
Approx. Weight (packaged) kg	26

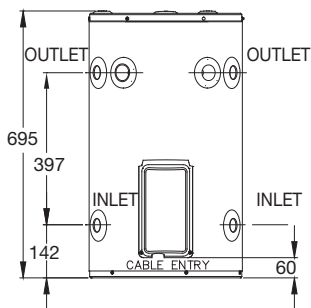

Tap QR code for
installation
instructions

